







Warning! Important Safety Instructions

Please read the Safety Instructions before using your TV.

Refer to the table below for an explanation of symbols which may be on your Samsung product.

CAUTION			Class II product: This symbol indicates that a safety connection to electrical earth (ground) is not required. If this symbol is not present on a product with a mains lead, the product MUST have a reliable connection to protective earth (ground).
RISK OF ELECTRIC SHOCK. DO NOT OPEN.			
CAUTION: TO REDUCE THE RISK OF ELECTRIC SHOCK, DO NOT REMOVE COVER (OR BACK). THERE ARE NO USER SERVICEABLE PARTS INSIDE. REFER ALL SERVICING TO QUALIFIED PERSONNEL.			AC voltage: Rated voltage marked with this symbol is AC voltage.
	This symbol indicates that high voltage is present inside. It is dangerous to make any kind of contact with any internal part of this product.		DC voltage: Rated voltage marked with this symbol is DC voltage.
	This symbol indicates that this product has included important literature concerning operation and maintenance.		Caution. Consult instructions for use: This symbol instructs the user to consult the user manual for further safety related information.

- The slots and openings in the cabinet and in the back or bottom are provided for necessary ventilation. To ensure reliable operation of this apparatus and to protect it from overheating, these slots and openings must never be blocked or covered.
 - Do not place this apparatus in a confined space, such as a bookcase or built-in cabinet, unless proper ventilation is provided.
 - Do not place this apparatus near or over a radiator or heat register, or where it is exposed to direct sunlight.
 - Do not place vessels (vases etc.) containing water on this apparatus, as this can result in a fire or electric shock.
- Do not expose this apparatus to rain or place it near water (near a bathtub, washbowl, kitchen sink, or laundry tub, in a wet basement, or near a swimming pool, etc.). If this apparatus accidentally gets wet, unplug it and contact an authorised dealer immediately.
- This apparatus uses batteries. In your community, there might be environmental regulations that require you to dispose of these batteries properly. Please contact your local authorities for disposal or recycling information.
- Do not overload wall outlets, extension cords, or adaptors beyond their capacity, since this can result in fire or electric shock.
- Power-supply cords should be placed so that they are not likely to be walked on or pinched by items placed upon or against them. Pay particular attention to cords at the plug end, at wall outlets, and at the point where they exit from the appliance.

- To protect this apparatus from a lightning storm, or when left unattended and unused for long periods of time, unplug it from the wall outlet and disconnect the antenna or cable system. This will prevent damage to the set due to lightning and power line surges.
- Before connecting the AC power cord to the DC adaptor outlet, make sure that the voltage designation of the DC adaptor corresponds to the local electrical supply.
- Never insert anything metallic into the open parts of this apparatus. This may cause a danger of electric shock.
- To avoid electric shock, never touch the inside of this apparatus. Only a qualified technician should open this apparatus.
- Be sure to plug in the power cord until it is firmly seated. When unplugging the power cord from a wall outlet, always pull on the power cord's plug. Never unplug it by pulling on the power cord. Do not touch the power cord with wet hands.
- If this apparatus does not operate normally - in particular, if there are any unusual sounds or smells coming from it - unplug it immediately and contact an authorised dealer or Samsung service centre.
- Be sure to pull the power plug out of the outlet if the TV is to remain unused or if you are to leave the house for an extended period of time (especially when children, elderly, or disabled people will be left alone in the house).
 - Accumulated dust can cause an electric shock, an electric leakage, or a fire by causing the power cord to generate sparks and heat or by causing the insulation to deteriorate.
- Be sure to contact an authorised Samsung service centre for information if you intend to install your TV in a location with heavy dust, high or low temperatures, high humidity, chemical substances, or where it will operate 24 hours a day such as in an airport, a train station, etc. Failure to do so may lead to serious damage to your TV.
- Use only a properly grounded plug and wall outlet.
 - An improper ground may cause electric shock or equipment damage. (Class I Equipment only.)
- To turn off this apparatus completely, disconnect it from the wall outlet. To ensure you can unplug this apparatus quickly if necessary, make sure that the wall outlet and power plug are readily accessible.
- Store the accessories (batteries, etc.) in a location safely out of the reach of children.
- Do not drop or strike the product. If the product is damaged, disconnect the power cord and contact a Samsung service centre.
- To clean this apparatus, unplug the power cord from the wall outlet and wipe the product with a soft, dry cloth. Do not use any chemicals such as wax, benzene, alcohol, thinners, insecticide, aerial fresheners, lubricants, or detergents. These chemicals can damage the appearance of the TV or erase the printing on the product.
- Do not expose this apparatus to dripping or splashing.
- Do not dispose of batteries in a fire.
- Do not short-circuit, disassemble, or overheat the batteries.
- **CAUTION:** There is danger of an explosion if you replace the batteries used in the remote with the wrong type of battery. Replace only with the same or equivalent type.

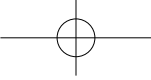

* Figures and illustrations in this User Manual are provided for reference only and may differ from the actual product appearance. Product design and specifications may change without notice. CIS languages (Russian, Ukrainian, Kazakhs) are not available for this product, since this is manufactured for customers in EU region.

English

WARNING

To prevent injury, this apparatus must be securely attached to the floor/wall in accordance with the installation instructions.

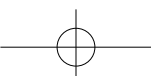
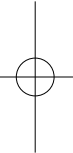
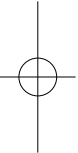

Contents

Before Reading This User Manual	2
Warning! Important Safety Instructions	3
01 What's in the Box?	
02 TV Installation	
Mounting the TV on a wall	9
Providing proper ventilation for your TV	10
Safety Precaution: Securing the TV to the wall to prevent falling	11
03 The Remote Control	
About the Buttons on the Remote Control	13
Installing batteries into the remote control (Battery size: AAA)	14
04 Running the Initial Setup	
Using the TV Controller	16
05 Changing the Input Source	
Source	16
How to use Edit Name	16
06 Connecting the "CI or CI+ Card" via COMMON INTERFACE slot	
Using the "CI or CI+ Card"	17

07 Main menu

Viewing the Menus	18
-------------------------	----

08 Troubleshooting and Maintenance

Troubleshooting	22
Teletext Feature	26
The teletext pages are organised according to six categories	27
Anti-theft Kensington Lock	27
Setting / Changing the TV's password	27
Caring for the TV	28

09 Specifications and Other Information

Specifications	29
Environmental Considerations	29
Decreasing power consumption	29
License	30

01 What's in the Box?

Make sure the following items are included with your TV. If any items are missing, contact your dealer.

- Remote Control & Batteries (AAA x 2)
- User Manual
- Warranty Card / Regulatory Guide (Not available in some locations)
- TV Power Cable
- The items' colours and shapes may vary depending on the models.
- Cables not included can be purchased separately.
- Check for any accessories hidden behind or in the packing materials when opening the box.

An administration fee may be charged in the following situations:

- (a) An engineer is called out at your request, but it is found that the product has no defect (i.e., where the user manual has not been read).
- (b) You bring the unit to the Samsung service centre, but it is found that the product has no defect (i.e., where the user manual has not been read).

You will be informed of the administration fee amount before a technician visits.



Warning: Screens can be damaged from direct pressure when handled incorrectly. We recommend lifting the TV at the edges, as shown.

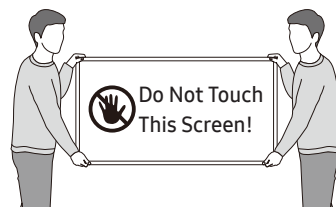

02 TV Installation

Mounting the TV on a wall



If you mount this TV on a wall, follow the instructions exactly as set out by the manufacturer. Unless it is correctly mounted, the TV may slide or fall and cause serious injury to a child or adult and serious damage to the TV.

- You can mount the TV on the wall using a wall mount kit (sold separately).
- Refer to the installation manual included with the Samsung wall mount kit.

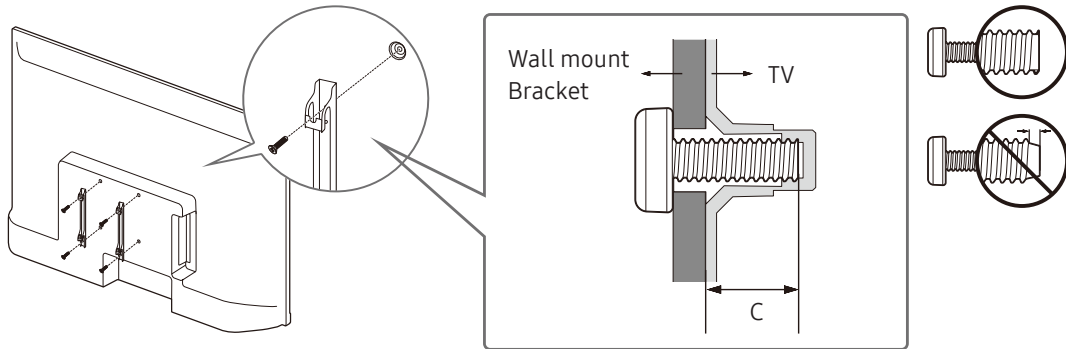

- Samsung Electronics is not responsible for any damage to the product or injury to yourself or others if you choose to install the wall mount on your own.
- You can install your wall mount on a solid wall perpendicular to the floor. Before attaching the wall mount to surfaces other than plaster board, contact your nearest dealer for additional information. If you install the TV on a ceiling or slanted wall, it may fall and result in severe personal injury.
- Standard dimensions for wall mount kits are shown in the table.
- If you are installing a third-party wall mount, note that the length of the screws you can use to attach the TV to the wall mount is shown in column C in the table.
- When installing a wall mount kit, we recommend you fasten all four VESA screws.
- If you want to install a wall mount kit that attaches to the wall using two top screws only, be sure to use a Samsung wall mount kit that supports this type of installation. (You may not be able to purchase this type of wall mount kit, depending on the geographical region.)

TV size in inches	VESA Screw hole specs (A * B) in millimetres	C (mm)	Standard Screw	Quantity	
32	100 x 100	6.0-8.0	M4	4	



Do not install your wall mount kit while your TV is turned on. This may result in personal injury from electric shock.

- Do not use screws that are longer than the standard dimension or do not comply with the VESA standard screw specifications. Screws that are too long may cause damage to the inside of the TV set.
- For wall mounts that do not comply with the VESA standard screw specifications, the length of the screws may differ depending on the wall mount specifications.
- Do not fasten the screws too firmly. This may damage the product or cause the product to fall, leading to personal injury. Samsung is not liable for these kinds of accidents.
- Samsung is not liable for product damage or personal injury when a non-VESA or non-specified wall mount is used or when the consumer fails to follow the product installation instructions.
- Do not mount the TV at more than a 15 degree tilt.
- Always have two people mount the TV onto a wall.

Providing proper ventilation for your TV

When you install your TV, maintain a distance of at least 10 cm between the TV and other objects (walls, cabinet sides, etc.) to ensure proper ventilation. Failing to maintain proper ventilation may result in a fire or a problem with the product caused by an increase in its internal temperature.

When you install your TV with a stand or a wall mount, we strongly recommend you use parts provided by Samsung Electronics only. Using parts provided by another manufacturer may cause difficulties with the product or result in injury caused by the product falling.

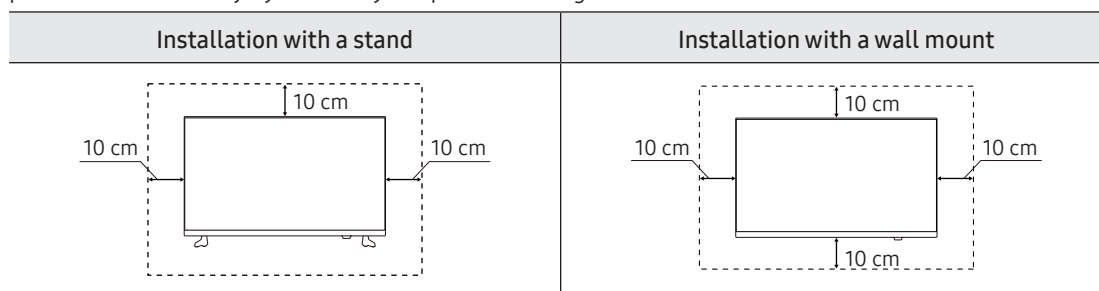

Safety Precaution: Securing the TV to the wall to prevent falling

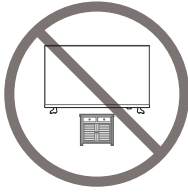

Caution: Pulling, pushing, or climbing on the TV may cause the TV to fall. In particular ensure your children do not hang on or destabilise the TV. This action may cause the TV to tip over, causing serious injuries or death. Follow all safety precautions provided in the Safety Flyer included with your TV. For added stability and safety, you can purchase and install the anti-fall device as described on the next page.



WARNING: Never place a television set in an unstable location. The television set may fall, causing serious personal injury or death. Many injuries, particularly to children, can be avoided by taking simple precautions such as

- Always use cabinets or stands or mounting methods recommended by the manufacturer of the television set.
- Always use furniture that can safely support the television set.
- Always ensure the television set is not overhanging the edge of the supporting furniture.
- Always educate children about the dangers of climbing on furniture to reach the television set or its controls.
- Always route cords and cables connected to your television so they cannot be tripped over pulled or grabbed.
- Never place a television set in an unstable location.
- Never place the television set on tall furniture (for example, cupboards or bookcases) without anchoring both the furniture and the television set to a suitable support.
- Never place the television set on cloth or other materials that may be located between the television set and supporting furniture.
- Never place items that might tempt children to climb, such as toys and remote controls, on the top of the television or furniture on which the television is placed.

If the existing television set is going to be retained and relocated, the same considerations as above should be applied.

Preventing the TV from falling

1. Using the appropriate screws, firmly fasten a set of brackets to the wall. Confirm that the screws are firmly attached to the wall.
 - You may need additional material such as wall anchors depending on the type of wall.
2. Using the appropriately sized screws, firmly fasten a set of brackets to the TV.
 - For the screw specifications, refer to the standard screw part in the table under “Mounting the TV on a wall”.
3. Connect the brackets fixed to the TV and the brackets fixed to the wall with a durable, heavy-duty string, and then tie the string tightly.
 - Install the TV near the wall so that it does not fall backwards.
 - Connect the string so that the brackets fixed to the wall are at the same height as or lower than the brackets fixed to the TV.

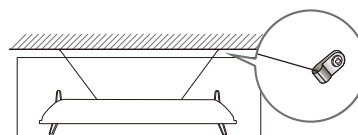
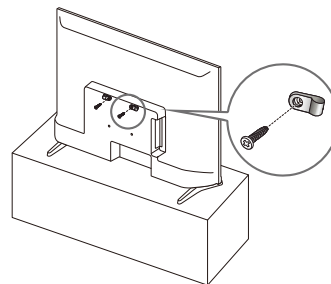

- The product colour and shape may vary depending on the model.

03 The Remote Control

About the Buttons on the Remote Control

- This remote control has Braille points on the Power, Channel, Volume, and Enter buttons and can be used by visually impaired persons.
- The images, buttons, and functions of the remote control may differ depending on the model.

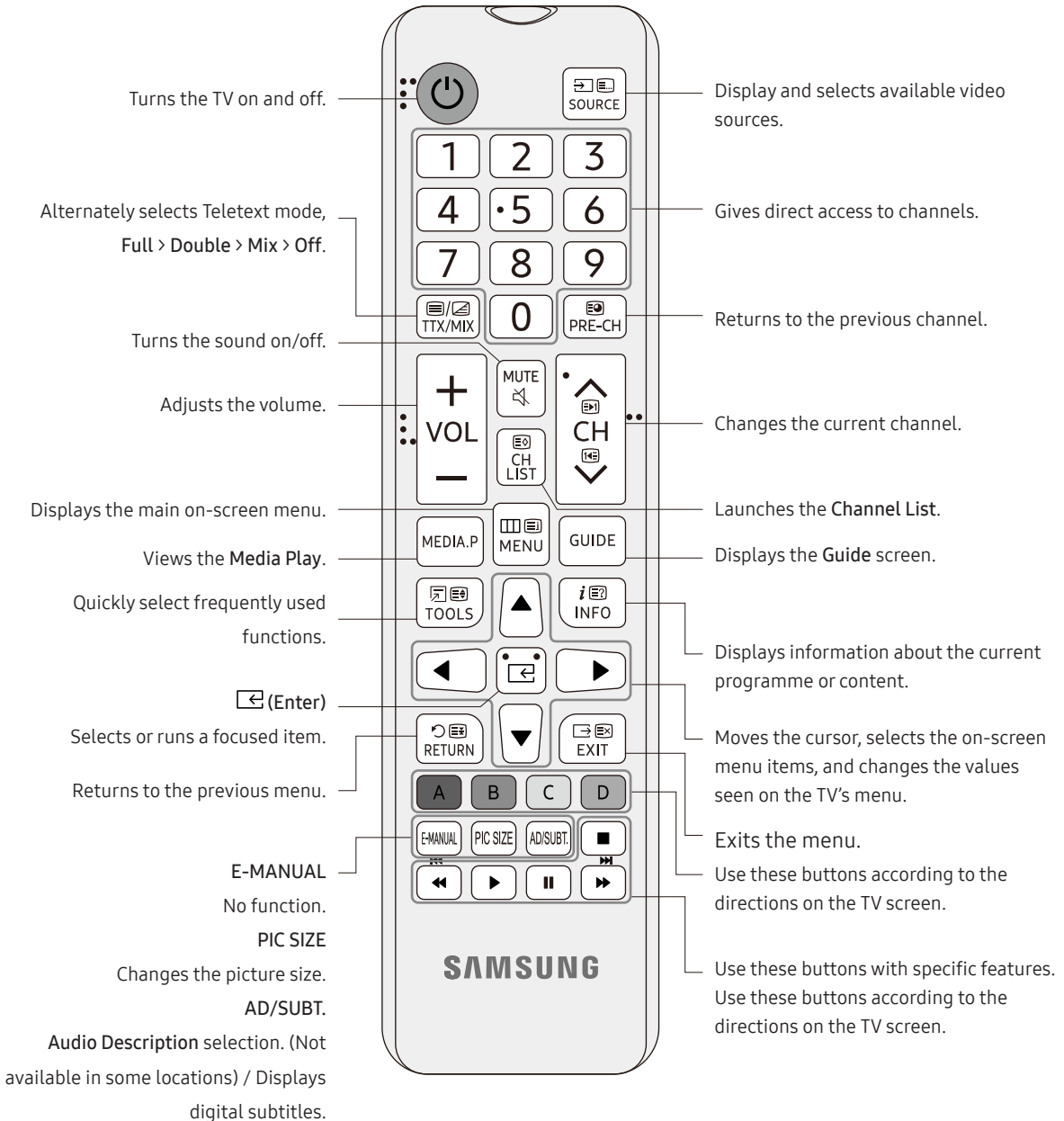

Installing batteries into the remote control (Battery size: AAA)

Match the polarities of the batteries to the symbols on the battery compartment.

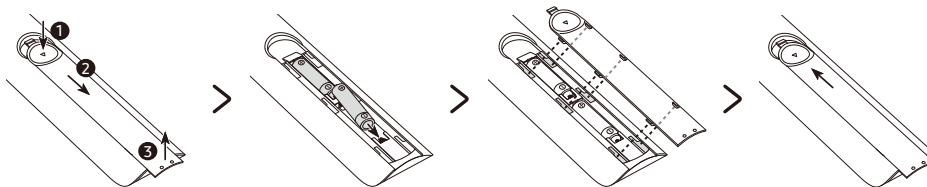

- The colour and shape of the remote may vary depending on the model.
 - Use the remote control within 7 m of the TV.
 - Bright lights may affect the performance of the remote control. Avoid using the remote control near special fluorescent lights or neon signs.
 - Alkaline batteries are recommended for longer battery life.
1. Gently pull on the battery cover's notch and then remove the cover completely once it comes loose.
 2. Insert 2 AAA alkaline batteries, making sure to align the positive and negative polarities correctly.
 3. Place the battery cover on the remote control and insert the cover into the remote control.
 4. Slide the battery cover in the order shown above so that the cover is completely attached to the remote control.

CAUTION

- Risk of explosion if the battery is replaced by an incorrect type.
- Replacement of a BATTERY with an incorrect type that can defeat a SAFEGUARD (for example, in the case of some lithium BATTERY types).
- Disposal of a BATTERY into fire or a hot oven, or mechanically crushing or cutting of a BATTERY, that can result in an EXPLOSION.
- Leaving a BATTERY in an extremely high temperature surrounding environment that can result in an EXPLOSION or the leakage of flammable liquid or gas.
- A BATTERY subjected to extremely low air pressure that may result in an EXPLOSION or the leakage of flammable liquid or gas.

04 Running the Initial Setup

When you turn on your TV for the first time, it immediately starts the Initial Setup. The Initial Setup allows you to configure the basic settings for the TV to operate, such as broadcast reception, channel search, at one time.

- Before starting the Initial Setup, be sure to connect external devices first.

You can also start the Initial Setup using the TV's menu (MENU  > System > Setup).

Follow the instructions displayed on the Initial Setup screen and configure the TV's basic settings to suit your viewing environment.

(The Initial Setup process may be differently displayed from your country.)

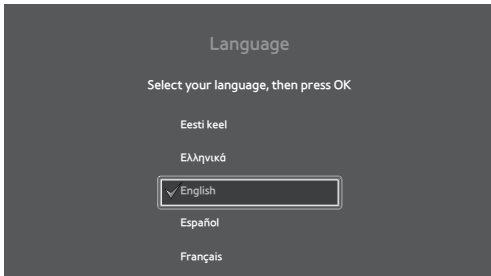

1. Select your language

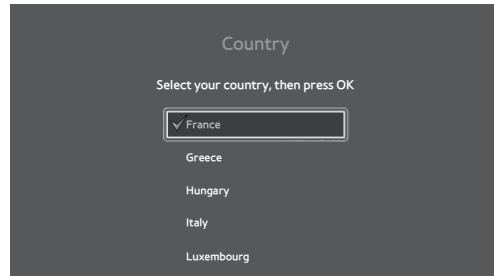

2. Select your country



3. Set the PIN code

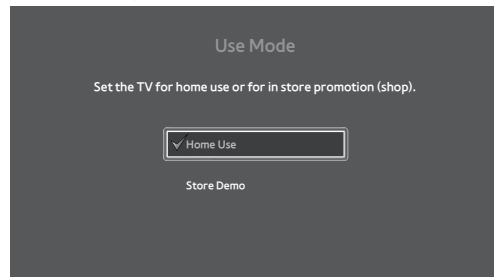

4. Select Use Mode



5. Start to install the TV

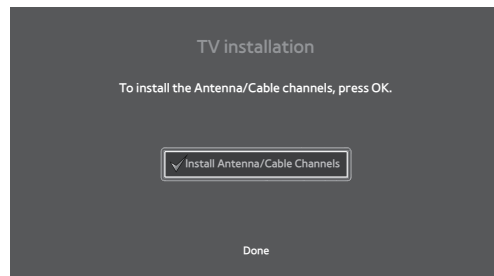

6. Start to scan channels

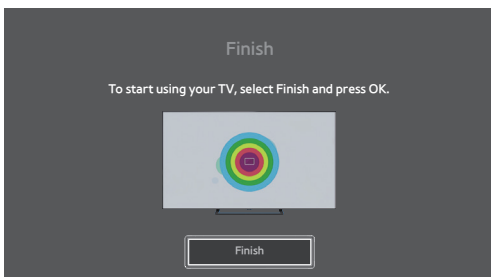

7. Finish

Using the TV Controller

You can turn on the TV with the TV Controller button at the bottom of the TV, and then use the Control menu.

The Control menu appears when the TV Controller button is pressed while the TV is On. For more information about its usage, refer to the figure below.

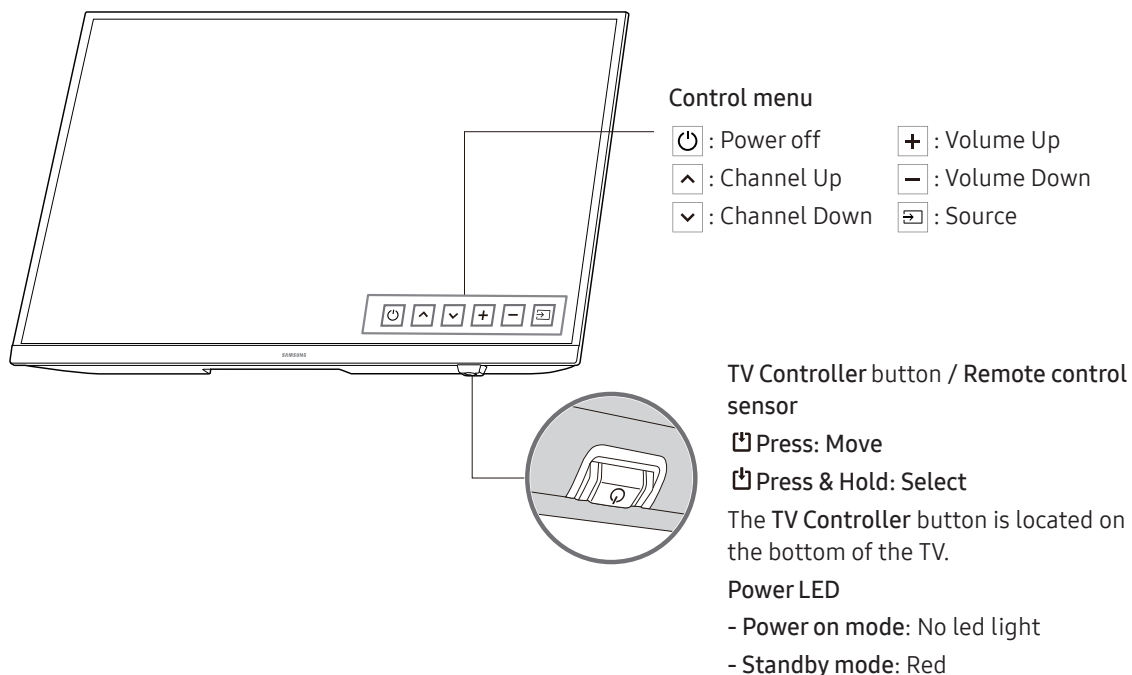

05 Changing the Input Source

Source

Use to select TV or other external input sources such as DVD / Blu-ray players / cable box / STB satellite receiver connected to the TV.

1. Press the SOURCE button on your remote.
2. Select a desired external input source.

How to use Edit Name

In the Source, press the Green button, and then you can set an external input sources name you want.

06 Connecting the “CI or CI+ Card” via COMMON INTERFACE slot

- Depending on the country and model.
 - Turn the TV off to connect or disconnect a “CI or CI+ Card”.
 - The TV Viewing Card (“CI or CI+ Card”) may not supported depending on the model.
- Connect the “CI or CI+ Card” to the COMMON INTERFACE slot as shown in the image below.

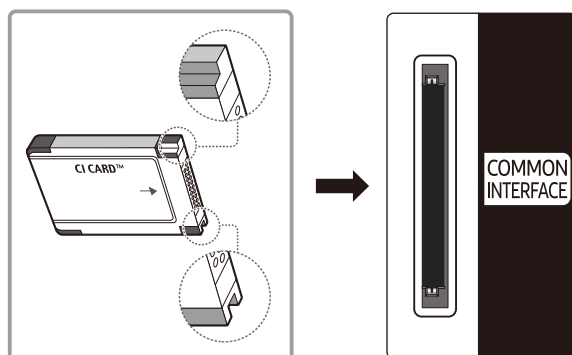

- The image may differ depending on the model.

Using the “CI or CI+ Card”

To watch paid channels, the “CI or CI+ CARD” must be inserted.

- Samsung TV follow up CI+ 1.3 standard. When TV product display the pop-up message, it may happen due to CI+ 1.3 Version inconsistency. If you have a problem, please contact Samsung Call Centre.
 - Your Samsung TV conforms to the CI+ 1.3 standards.
 - Where a CI+ Common Interface module is incompatible with TV product then please remove the module and contact the CI+ operator for assistance.
 - If you don’t insert the “CI or CI+ CARD”, some channels will display the pop-up message.
- The pairing information containing a telephone number, the “CI or CI+ CARD” ID, the Host ID, and other information will be displayed in about 2~3 minutes. If an error message is displayed, please contact your service provider.
 - You must obtain a “CI or CI+ CARD” from a local cable service provider.
 - When removing the “CI or CI+ CARD”, carefully pull it out with your hands since dropping the “CI or CI+ CARD” may cause damage to it.
 - Insert the “CI or CI+ CARD” in the direction marked on the card.
 - The location of the COMMON INTERFACE slot may be different depending on the model.
 - “CI or CI+ CARD” is not supported in some countries and regions. Check with your authorised dealer.
 - If you have any problems, please contact a service provider.
 - Insert the “CI or CI+ CARD” that supports the current aerial settings. If not, the screen may not look normal.

07 Main menu

Viewing the Menus

With the power on, press the **MENU** button. The main menu appears on the screen. Its left side has five icons: **Picture**, **Sound**, **Broadcasting**, **System**, and **Support**.

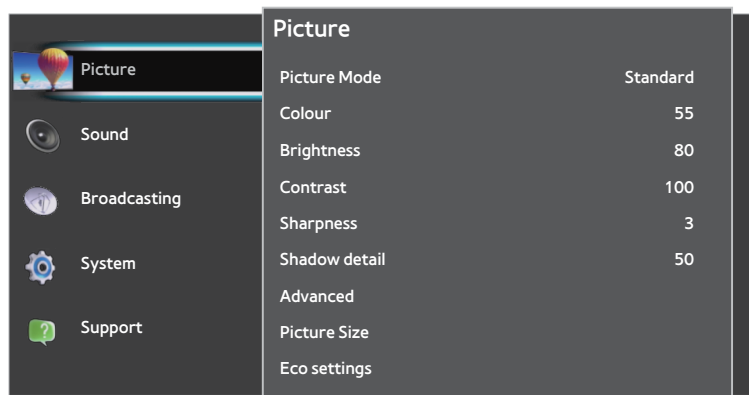

Item	Description	
Picture	Picture Mode	Select your preferred picture type. <ul style="list-style-type: none"> • Dynamic: Suitable for a bright room. • Standard: Suitable for a normal environment. • Movie: Suitable for watching movies in a dark room.
	Colour	Adjust the colour saturation according to your personal preference.
	Brightness	Adjust the video backlight intensity.
	Contrast	Adjust the level of contrast for best picture experience.
	Sharpness	Adjust picture sharpness.
	Shadow detail	Adjust the entire brightness of the video signals.
	Advanced	Adjust the detailed setting for the screen including colour and contrast. <ul style="list-style-type: none"> • Computer: Set to have the ideal picture settings for using your TV as a computer monitor. (Only available when the HDMI source is selected) • Colour enhancement: Set the level of enhancement for colour intensity and details in bright colours. • Colour Tone: Set the colour tone manually. • Custom Colour Tone: Set the overall colour tone manually. (Only available when the Custom is selected in Colour Tone) • Motion Lighting: Reduce power consumption by brightness control adapted motion. • Dynamic Contrast: Adjust the level at which the TV automatically enhances the details in the dark, middle and light areas of the picture. • Gamma: Adjust the primary colour intensity. This is an expert user setting. • Digital Clean View: Reduce unwanted picture noise. • MPEG Noise Filter: Reduce MPEG noise to improve picture quality.

Item	Description	
Picture	Picture Size	Set the various picture options such as picture size and aspect ratio. <ul style="list-style-type: none"> – The available items may differ depending on the selected mode. – Depending on the input source, the picture size options may vary. • Picture format: Select the picture format that fills the screen. • Screen edges: Set to slightly enlarge the picture to hide distorted edges. • Picture shift: Shift the picture position with the cursor keys. <ul style="list-style-type: none"> – It is available when the HDMI source is selected. For ATV / DTV, it depends on the Picture Size and signal (SD / HD).
	Eco settings	Eco settings bundles settings that help save energy. <ul style="list-style-type: none"> • Energy saving: Set energy saving level. • Screen off: Set screen off to save energy consumption. • Switch off timer: Set TV switch off timer. Press to adjust the value. The value 0 (Off) deactivates the automatic switch off.
Sound	Sound Mode	Select your favourite sound mode. <ul style="list-style-type: none"> • User: Adjust the sounds manually to suit your preferred sound quality. • Standard: Select the normal sound mode. • Cinema: Provide the best sound for movies. • Music: Provide the best sound for watching music videos, etc. • Game: Provide the best sound for playing games, etc. • Speech: Provide the best sound for watching news, drama, etc.
	Bass	Adjust low tones in the sound.
	Treble	Adjust high tones in the sound.
	Surround mode	Select surround sound settings.
	Clear Sound	Select to improve the sound for speech. Ideal for news programme.
	Advanced	Adjust the advanced sound settings individually. <ul style="list-style-type: none"> • Auto volume levelling: This function allows you to reduce the disparity of a voice signal (which is one of the signals received during a digital TV broadcast) to a desired level. • Delta volume: Adjust the delta value for TV speaker volume. (Only available when the ATV or HDMI source is selected) • Audio out: Set the TV to play the sound on TV or on the connected audio system. • Digital out format: You can select the Digital Audio output format. The available Digital Audio output format may differ depending on the input source.

Item	Description	
Sound	Advanced	<ul style="list-style-type: none"> • Digital out levelling: Level out the volume from device which is connected to DIGITAL AUDIO OUT(OPTICAL). • Digital out delay: Adjust the delay time of the sound output from DIGITAL AUDIO OUT(OPTICAL) terminal. • Digital out offset: Set an audio offset If you cannot set a sound delay on the Home Theatre System. (Only available when Digital out delay set to On)
Broadcasting	Search for channels	Start updating the current channels or redo a complete installation channels.
	Automatic channel update	Automatically search for the receivable channels.
	Channel update message	When new channels are found, a message is shown at TV start up.
	Digital: Reception test	Manually install digital channels. If the reception is poor, check and reposition your antenna. Select Search to check the signal quality.
	Analogue: Manual installation	Manually install analogue channels. <ul style="list-style-type: none"> • System: Select the country and the TV system. • Search Channel: Enter a frequency to find a channel. • Fine tune: Fine tune a channel. • Store current channel / Store as new channel: Store a found channel on the current channel number or as a new channel number.
	Common interface	If prepaid premium content is available from a CAM, you can set the provider settings with this option. (Only available when you insert CAM card)
System	Use Mode	Select the Use Mode suitable for your place. <ul style="list-style-type: none"> • Home Use: It is the default setting. • Store Demo: It is for retail environments only. If you select Store Demo, Picture Mode will change to Dynamic every 10 minutes.
	Shop setup	<ul style="list-style-type: none"> • Feature logos: Select On / Off to show the e-sticker. (Only available when the Store Demo is selected in Use Mode)
	Factory settings	It will reset all the personal settings. The channel installation remains unchanged.
	Setup	Reinstall and redo the TV installation completely.
	CAM Operator profile	This enables the user to allow the CI+CAM operator profile which is for easy channel installation and updating.
	CAM Profile Name	Show the current using CAM profile name. (Only available when you insert CAM card)

Item	Description	
System	Time	<ul style="list-style-type: none"> • Clock Mode: Set the Date and Time to automatic, manual or country dependent time adjustment. • Time Zone: Set your local time zone. <ul style="list-style-type: none"> – This is only for Spain and Portugal. (Only available when the Country dependent is selected in Clock Mode) • Daylight saving: Set the daylight saving option. (Only available when the Country dependent is selected in Clock Mode) • Sleep timer: Set the TV to switch to Standby automatically after a preset time.
	Languages	Select the language for the TV menus or the preferred languages for audio, subtitles and Text/Teletext.
	Universal access	Activate special function for aid visually-impaired and hearing-impaired people.
	Hearing impaired	Some digital TV programmes broadcast special audio and subtitle for the hard of hearing or deaf people.
	Audio description	Set On to activate special audio commentary describing what is happening on screen.
	Parental rating	Prevent unauthorised users, such as children, from watching unsuitable programme with a user-defined 4-digit PIN code.(Depending on the broadcaster)
	Set code / Change code	<p>You can set / change the PIN number.</p> <ul style="list-style-type: none"> – You must enter the 4 digit PIN code when running the initial setup. If not, it will need to Set code first.
Support	Current software info	View the current software version and information.
	Local updates	For dealers and expert users.
	Look for OAD updates	Search for an Over-the-air software update. (It depends on your country.)
	View software update history	Display the list of software update history.
	OSS	View the open source license.
	Contact Samsung	You can find information regarding our call centres, and product information and software version.
	Self Diagnosis	Test the TV picture, sound and signal.

08 Troubleshooting and Maintenance

Troubleshooting

If the TV seems to have a problem, first try this list of possible problems and solutions. If none of these troubleshooting tips apply, visit “www.samsung.com”, then click on Support, or call Samsung customer service centre.

Picture Quality

- First of all, please perform the **Picture Test** and confirm that your TV is properly displaying test image. (go to **MENU**  - **Support** - **Self Diagnosis** - **Picture Test**) If the test image is properly displayed, the poor picture may be caused by the source or signal.



The TV image does not look as good as it did in the store.

- If you have an analogue cable box or satellite box, upgrade to a digital cable box or satellite box. Use HDMI cables to deliver HD (high definition) picture quality.
- Cable/Satellite subscribers: Try digital stations from the channel line up.
- Aerial connection: Try HD stations after performing **Search for channels**.
- Many HD channels are up scaled from SD (Standard Definition) contents.
- Adjust the cable box or satellite box video output resolution to 1080i or 720p.
- Make sure you are watching the TV at the minimum recommended distance based on the size and definition of the signal.

The picture is distorted: macro block, small block, dots, pixelisation error.

- Compression of video contents may cause picture distortion especially in fast moving pictures such as sports and action movies.
- Low signal level or bad quality can cause picture distortion. This is not a TV issue.
- Mobile phones used close to the TV (cca up to 1m) may cause noise in picture on analogue and digital TV.

There is poor colour or brightness.

- Adjust the **Picture** options in the TV menu. (go to **Picture Mode** / **Colour** / **Brightness** / **Contrast** / **Sharpness** / **Shadow detail**)
- Adjust **Energy saving** option in the TV menu. (go to **MENU**  - **Picture** - **Eco settings** - **Energy saving**)
- Try resetting the picture to view the default picture settings. (go to **MENU**  - **Picture** - **Picture Mode**, then press  **Reset to Defaults**)

There is a dotted line on the edge of the screen.

- If the picture size is set to **Auto fill**, change it to **16:9 Overscan**.
- Change the cable box or satellite box resolution.

When changing channels, the picture freezes or is distorted or delayed.

- If connected with a cable box or satellite box, please try to reset the cable box or satellite box. Reconnect the AC power cord and wait until the cable box or satellite box reboots. It may take up to 20 minutes.

- Set the output resolution of the cable box or satellite box to 1080i or 720p.

Sound Quality

- First of all, please perform the **Sound Test** to confirm that your TV audio is properly operating. (go to MENU ▢ - Support - Self Diagnosis - Sound Test)
- If the audio is ok, the sound problem may be caused by the source or signal.

There is no sound or the sound is too low at maximum volume.

- Please check the volume of the device (cable box or satellite box, DVD, Blu-ray etc) connected to your TV.

The picture is good but there is no sound.

- Set the **Audio out** option to **TV speakers** in the sound menu. (go to MENU ▢ - Sound - Advanced - Audio out)
- If you are using an external device, check the device's audio output option (ex. you may need to change your cable box's or satellite box's audio option to HDMI when you have a HDMI connected to your TV).
- If you are using a DVI to HDMI cable, a separate audio cable is required.
- Reboot the connected device by reconnecting the device's power cable.

The speakers are making an inappropriate noise.

- For aerial or cable connections, check the signal strength. Low signal level may cause sound distortion. (go to MENU ▢ - Support - Self Diagnosis - Signal Information)

No Picture, No Video

The TV will not turn on.

- Make sure the AC power cord is securely plugged in to the wall outlet and the TV.
- Make sure the wall outlet is working.
- Try pressing the **POWER** (⏻) button at the bottom of the TV to make sure the problem is not the remote. If the TV turns on, refer to "The remote control does not work".

The TV turns off automatically.

- Ensure the **Sleep Timer** is set to **Off** in the Time menu. (go to MENU ▢ - System - Time - Sleep timer)
- If your PC is connected to the TV, check your PC power settings.
- Make sure the AC power cord is plugged in securely to the wall outlet and the TV.
- **Switch off timer** turns off the TV if there has been no user input in 240 minutes (default). You can set the time to up to 240 minutes in increments of 30 minutes. (go to MENU ▢ - Picture - Eco settings - Switch off timer)

There is no picture/video.

- Check cable connections (remove and reconnect all cables connected to the TV and external devices).
- Set your external device's (cable box or satellite box, DVD, Blu-ray etc) video outputs to match the connections to the TV input. For example, if an external device's output is HDMI, it should be connected to an HDMI input on the TV.

- Make sure your connected devices are powered on.
- Be sure to select the TV's correct source by pressing the **SOURCE** button on the remote control.
- Reboot the connected device by reconnecting the device's power cable.

Aerial (Air/Cable) Connection (Cable: depending on the country)

The TV is not receiving all channels.

- Make sure the Aerial cable is connected securely.
- Please try **Setup** (Initial setup) to add available channels to the channel list. Go to **MENU** [] - **System - Setup** (Initial setup) and wait for all available channels to be stored.
- Verify the Aerial is positioned correctly.
- Try to start a channel update manually (go to **MENU** [] - **Broadcasting - Search for channels - Update channels**) or re-install channels. (go to **MENU** [] - **Broadcasting - Search for channels - Re-install channels**)

The picture is distorted: macro block, small block, dots, pixelisation error.

- Compression of video contents may cause picture distortion, especially on fast moving pictures such as sports and action movies.
- A low signal can cause picture distortion. This is not a TV issue.

Others

The picture will not display in full screen.

- HD channels will have black bars on either side of the screen when displaying up scaled SD (4:3) contents.
- Black bars on the top and bottom will appear during movies that have aspect ratios different from your TV.
- Adjust the picture size options on your external device or TV to full screen.

The remote control does not work.

- Replace the remote control batteries with the poles (+/-) in the right direction.
- Clean the sensor's transmission window on the remote.
- Try pointing the remote directly at the TV from 1.5 ~ 1.8 m away.

The cable box or satellite box remote control doesn't turn the TV on or off, or adjust the volume.

- Programme the cable box or satellite box remote control to operate the TV. Refer to the cable box or satellite box user manual for the SAMSUNG TV code.

There is a plastic smell from the TV.

- This smell is normal and will dissipate over time.

The TV Signal Information is unavailable in the Self Diagnosis Test menu.

- This function is only available with digital channels from an Aerial / RF / Coax connection.

TV is tilted to the right or left side.

- Remove the stand base from the TV and reassemble it.

There are difficulties assembling the stand base.

- Make sure the TV is placed on a flat surface. If you can not remove the screws from the TV, please use a

magnetised screw driver.

The CI+ does not work.

- Your Samsung TV conforms to the CI+ 1.3 standards.
- Where a CI+ Common Interface module is incompatible with TV product then please remove the module and contact the CI+ operator for assistance.

Picture mode will change to Dynamic every 10 minutes.

- If the TV is in the **Store Demo** mode, it will reset the **Picture Mode** to **Dynamic** every 10 minutes. If you want to change the settings from **Store Demo** mode to **Home Use** mode, press the **SOURCE** button to select TV mode, and go to **MENU**  - **System** - **Use Mode**.

You have intermittent loss of audio or video.

- Check the cable connections and reconnect them.
- Loss of audio or video can be caused by using overly rigid or thick cables. Make sure the cables are flexible enough for long term use. If mounting the TV to the wall, we recommend using cables with 90 degree connectors.

You see small particles when you look closely at the edge of the frame of the TV.

- This is part of the product's design and is not a defect.

There are recurrent picture/sound issues.

- Check and change the signal/source.

A reaction may occur between the rubber cushion pads on the base stand and the top finish of some furniture.

- To prevent this, use felt pads on any surface of the TV that comes in direct contact with furniture.

You can keep your TV in optimum operating condition by upgrading to the latest firmware (www.samsung.com → Support) by USB.

1. Insert a USB drive containing the firmware upgrade file into the TV.
2. Go to **MENU**  - **Support** – **Local updates** and select the firmware file.
3. Select **Start** to start the software update.
4. Select **Restart** to restart TV.
 - Please be careful not to disconnect the power or remove the USB drive until upgrades are complete.
 - The TV will be turned off and on automatically after completing the firmware upgrade.
 - Please remember to unplug USB after firmware upgrade.
 - USB format should be FAT32.

This TFT LED panel uses a panel consisting of sub pixels which require sophisticated technology to produce.

However, there may be a few bright or dark pixels on the screen. These pixels will have no impact on the performance of the product.

Some functions and pictures shown in this manual are available on specific models only.

Teletext Feature

- To enter the Teletext feature, press the TTX/MIX button on the remote control.
- To exit from the Teletext feature, press the TTX/MIX button on the remote control until live TV appears.
- This function is available only in the channel that supports the teletext service.
- This function may not be supported depending on the model or geographical area.

The index page of the Teletext service gives you information on how to use the service. For Teletext information to be displayed correctly, channel reception must be stable. Otherwise, information may be missing or some pages may not be displayed.

- You can change Teletext pages by pressing the numeric buttons on the remote control.

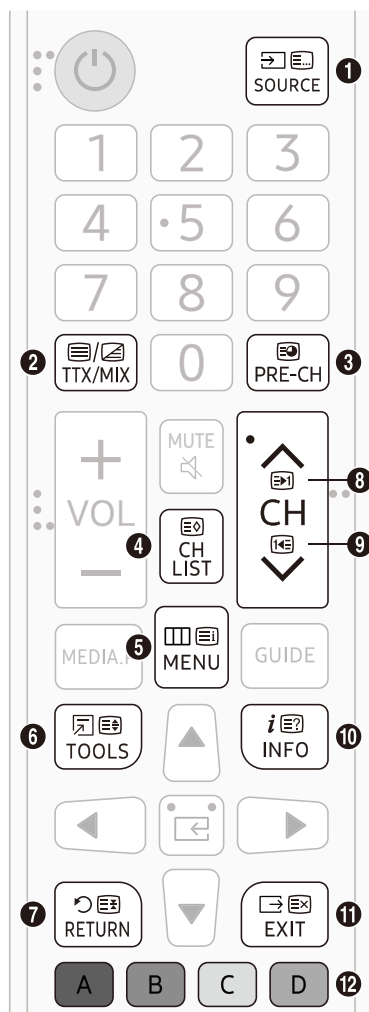

- 1 List/Flof: No function
- 2 Full TTX / Double TTX / Mix / Off: The teletext mode is activated in the channel that is being watched. Each time you press the button, the teletext mode changes in the order of Full TTX → Double TTX → Mix → Off.
- 3 Sub Page: Displays the available sub-page.
- 4 Store: No function
- 5 Index: Displays the index (contents) page at any time while you are viewing Teletext.
- 6 Size: Displays the teletext on the upper half of the screen in double-size. To move the text to the lower half of the screen, press it again. For normal display, press it once again.
- 7 Hold: Holds the display at the current page, in the case that there are several secondary pages that follow automatically. To undo, press it again.
- 8 Page Up: Displays the next Teletext page.
- 9 Page Down: Displays the previous Teletext page.
- 10 Reveal/Conceal: Displays or hides the hidden text (answers to quiz games, for example). To display the normal screen, press it again.
- 11 Cancel: Shrinks the Teletext display to overlap with the current broadcast.
- 12 **Colour buttons (red, green, yellow, blue):** If the FASTEXT system is used by the broadcasting company, the different topics on a Teletext page are colour-coded and can be selected by pressing the coloured buttons. Press the colour corresponding to the topic of your choice. A new colour coded page is displayed. Items can be selected in the same way. To display the previous or next page, press the corresponding coloured button.

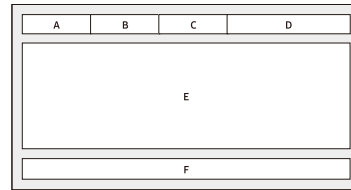

The teletext pages are organised according to six categories

Part	Contents
A	Selected page number.
B	Broadcasting channel identity.
C	Current page number or search indications.
D	Date and time.
E	Text.
F	Status information. FASTEXT information.



Anti-theft Kensington Lock

The Kensington Lock is not supplied by Samsung. It is a device used to physically fix the system when using it in a public place. The appearance and locking method may differ from the illustration depending on the manufacturer. Refer to the manual provided with the Kensington Lock for additional information on proper use.

- Please find a “” icon on the rear of the TV. A Kensington slot is beside the “” icon.
- The position and colour may differ depending on the model.

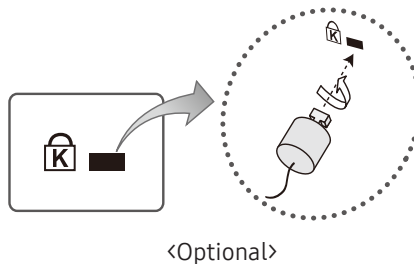

To lock the product, follow these steps:

1. Wrap the Kensington lock cable around a large, stationary object such as desk or chair.
2. Slide the end of the cable with the lock attached through the looped end of the Kensington lock cable.
3. Insert the locking device into the Kensington slot on the product.
4. Lock the lock.
 - These are general instructions. For exact instructions, see the User manual supplied with the locking device.
 - The locking device has to be purchased separately.

Setting / Changing the TV's password

MENU  - System - Set code / Change code

1. Run **Change code** and then enter the current password in the password field. The default password is “9999”.
2. Enter a new password and then enter it again to confirm it. The password change is complete.

Caring for the TV

- If a sticker was attached to the TV screen, some debris can remain after you remove the sticker. Please clean the debris off before watching TV.
- The exterior and screen of the TV can get scratched during cleaning. Be sure to wipe the exterior and screen carefully using a soft cloth to prevent scratches.
- Do not spray water or any liquid directly onto the TV. Any liquid that goes into the product may cause a failure, fire, or electric shock.
- To clean the screen, turn off the TV, then gently wipe away smudges and fingerprints on the panel with a micro-fiber cloth. Clean the body or panel of the TV with a micro-fiber cloth dampened with a small amount of water. After that, remove the moisture with a dry cloth. While cleaning, do not apply strong force to the surface of the panel because it can damage the panel. Never use flammable liquids (benzene, thinner, etc.) or a cleaning agent. For stubborn smudges, spray a small amount of screen cleaner on a micro-fiber cloth, and then use the cloth to wipe away the smudges.

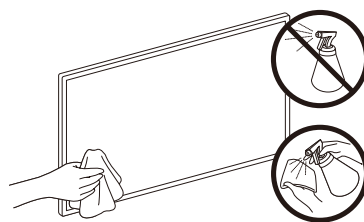

09 Specifications and Other Information

Specifications

Model Name	UE32T4005AK / UE32T4000AK / UE32T4000AW / UE32T4002AK
Display Resolution	1366 x 768
Screen Size	31.5 inches
Measured Diagonally	80 cm
Sound (Output)	5 W + 5 W
Dimensions (W x H x D)	
Body	719.2 x 434.7 x 88.6 mm
With stand	719.2 x 464.4 x 166.0 mm
Weight	
Without Stand	4.1 kg
With Stand	4.2 kg

Environmental Considerations

Operating Temperature	10°C to 40°C (50°F to 104°F)
Operating Humidity	10% to 80%, non-condensing
Storage Temperature	-20°C to 45°C (-4°F to 113°F)
Storage Humidity	5% to 95%, non-condensing

- The design and specifications are subject to change without prior notice.
- For information about the power supply, and more information about power consumption, refer to the label-rating attached to the product.
- Typical power consumption is measured according to IEC 62087.
- You can see the label-rating attached to the back of the TV. (For some models, you can see the label-rating inside the cover terminal.)

Decreasing power consumption

When you shut the TV off, it enters Standby mode. In Standby mode, it continues to draw a small amount of power. To decrease power consumption, unplug the power cord when you don't intend to use the TV for a long time.

License



The terms HDMI and HDMI High-Definition Multimedia Interface, and the HDMI Logo are trademarks or registered trademarks of HDMI Licensing LLC in the United States and other countries.



Dolby, Dolby Audio, and the double-D symbol are trademarks of Dolby Laboratories. Manufactured under license from Dolby Laboratories. Confidential unpublished works. Copyright © 1992-2020 Dolby Laboratories. All rights reserved.



Recommendation - EU Only



Hereby, Samsung Electronics, declares that this equipment is in compliance with the essential requirements and other relevant provisions of Directives 2014/53/EU (RED), 2009/125/EC (Eco Design) and 2011/65/EU (RoHS).

The full text of the EU declaration of conformity is available at the following internet address: <http://www.samsung.com> go to Support and enter the model name.

This equipment may be operated in all EU countries.



**Correct Disposal of This Product (Waste Electrical & Electronic Equipment)
(Applicable in countries with separate collection systems)**

This marking on the product, accessories or literature indicates that the product and its electronic accessories (e.g. charger, headset, USB cable) should not be disposed of with other household waste at the end of their working life. To prevent possible harm to the environment or human health from uncontrolled waste disposal, please separate these items from other types of waste and recycle them responsibly to promote the sustainable reuse of material resources.

Household users should contact either the retailer where they purchased this product, or their local government office, for details of where and how they can take these items for environmentally safe recycling.

Business users should contact their supplier and check the terms and conditions of the purchase contract. This product and its electronic accessories should not be mixed with other commercial wastes for disposal.



**Correct disposal of the batteries in this product
(Applicable in countries with separate collection systems)**

This marking on battery, manual or packaging indicates that the batteries in this product should not be disposed of with other household waste at the end of their working life. Where marked, the chemical symbols Hg, Cd or Pb indicate that the battery contains mercury, cadmium or lead above the reference levels in EC Directive 2006/66. If batteries are not properly disposed of, these substances can cause harm to human health or the environment.

To protect natural resources and to promote material reuse, please separate batteries from other types of waste and recycle them through your local, free battery return system.

For information on Samsung's environmental commitments and product-specific regulatory obligations, e.g. REACH, WEEE, Batteries, visit www.samsung.com/uk/aboutsamsung/sustainability/environment/our-commitment/data/

WARNING - TO PREVENT THE SPREAD OF FIRE, KEEP CANDLES OR OTHER ITEMS WITH OPEN FLAMES AWAY FROM THIS PRODUCT AT ALL TIMES.



Supported Media File

Internal Subtitle

File Extension	Container	Subtitle Codec	Remark
mpg, mpeg, vob	MPG, MPEG	DVD Subtitle	
ts, tp	TS	DVB Subtitle	
mp4	MP4	DVD Subtitle UTF-8 Plain Text	
mkv	MKV	ASS SSA UTF-8 Plain Text VobSub DVD Subtitle	
avi	AVI(1.0, 2.0), DMF0,1,2	XSUB XSUB+	

External Subtitle

File Extension	Subtitle Parser	Remark
.srt	SubRip	
.ssa/ .ass	SubStation Alpha	
.smi	SAMI	
.sub	SubViewer MicroDVD DVDSubtitleSystem SubIdx (VobSub)	SubViewer 1.0 & 2.0 Only
.txt	TMPlayer	

Supported Video Formats

Video Codec	Resolution	Bit Rate	Profile	Container
MPEG1/2	1080P@30fps	40Mbps	MP@HL	MPEG program stream (.VOB, .MPG, .MPEG) MPEG transport stream (.ts, .tp) MP4 (.mp4, .mov) AVI (.avi) MKV (.mkv) ASF (wmv)
MPEG4	1080P@30fps	40Mbps	. Simple Profile . Advanced Simple Profile@Level 5 . GMC is not supported	MPEG program stream (.MPG, .MPEG) MP4 (.mp4, .mov) AVI (.avi) MKV (.mkv) ASF (wmv)
Sorenson H.263	1080P@30fps	40Mbps		AVI (.avi) SWF(.swf)
H.263	1080P@30fps	40Mbps		MP4 (.mp4, .mov) AVI (.avi) MKV (.mkv)

Video Codec	Resolution	Bit Rate	Profile	Container
H.264	1080P@60fps	50Mbps	. Main Profile . High Profile @ Level 4.1 bit rate up to 50Mbps	MP4 (.mp4, .mov) MPEG transport stream (.ts, .tp) ASF (.asf) WMV (.wmv) AVI (.avi) MKV (.mkv)
AVS	1080P@30fps	40Mbps	Jizhun profile @ Level 6.0	MPEG transport stream (.ts, .tp)
WMV3	1080P@30fps	40Mbps		ASF (.wmv) AVI (.avi) MKV (.mkv) WMV (.wmv)
VC1	1080P@30fps	40Mbps	. Advanced Profile @ Level 3 . Simple Profile . Main Profile	MPEG program stream (.MPG, .MPEG) MPEG transport stream (.ts, .tp) WMV (.wmv) AVI (.avi) MKV (.mkv)
Motion JPEG	640x480@30fps	10Mbps		AVI (.avi) MP4 (.mp4, .mov) MKV (.mkv)
HEVC/H.265	1080P@60fps, High tier	50Mbps	Main / Main10 profile @Level4.1	MP4 (.mp4, .mov) MPEG transport stream (.ts, .tp) MKV (.mkv)

Supported Photo Formats

Image	Photo	Resolution (width x height)	Remark
JPEG	Base-line	15360 x 8640 (1920x8 x 1080x8)	The limitation of max resolution depends on DRAM size
	Progressive	1024x768	The limitation of max resolution depends on DRAM size
PNG	non-interlace	9600x6400	The limitation of max resolution depends on DRAM size
	interlace	1200x800	The limitation of max resolution depends on DRAM size
BMP		9600x6400	The limitation of max resolution depends on DRAM size
MPO	Base-line	15360x8640 (1920x8 x 1080x8)	The limitation of max resolution depends on DRAM size
	Progressive	1024x768	The limitation of max resolution depends on DRAM size
GIF		6400x4800 (800x8 x 600x8)	The limitation of max resolution depends on DRAM size

1. Resolution is a kind of reference design, instead of hardware limitation. Because it is bounded by DRAM size and performance
2. The larger resolution, the bigger DRAM size
3. The larger resolution, the less performance, since it requires longer time to show a picture
4. JPEG use hardware decoder. The max resolution of Jpeg hardware decoder is 16360x16360
5. BMP decoder is a software decoder. The limitation of max resolution depends on DRAM size
6. PNG decoder is a software decoder. The limitation of max resolution depends on DRAM size
7. GIF decoder is a software decoder. The limitation of max resolution depends on the DRAM size

Supported Audio Formats

Audio Codec	Sample rate	Channel	Bit Rate	Container	Remark
MPEG1/2 Layer1	16KHz ~ 48KHz	Up to 2	32Kbps ~ 448Kbps	Movie: AVI (.avi) ASF (wmv) Matroska (.mkv) MPEG transport stream (.ts, .tp) MPEG program stream (.MPG, .MPEG) Music: WAV (.wav) MP3 (.mp3)	
MPEG1/2 Layer2	16KHz ~ 48KHz	Up to 2	8Kbps ~ 384Kbps	Movie: AVI (.avi) ASF (.wmv) Matroska (.mkv) MPEG transport stream (.ts, .tp) MPEG program stream (.MPG, .MPEG) Music: WAV (.wav) MP3 (.mp3)	
MPEG1/2 Layer3	16KHz ~ 48KHz	Up to 2	8Kbps ~ 320Kbps	Movie: AVI (.avi) ASF (.wmv) Matroska (.mkv) MP4 (.mp4, .mov) MPEG transport stream (.ts, .tp) MPEG program stream (.MPG, .MPEG) SWF (.swf) Music: WAV (.wav) MP3 (.mp3) MP4 (.m4a)	
AC3	32KHz, 44.1KHz, 48KHz	Up to 5.1	32Kbps ~ 640Kbps	Movie: AVI (.avi) Matroska (.mkv) MP4 (.mp4, .mov) MPEG transport stream (.ts, .tp) MPEG program stream (.MPG, .MPEG) Music: AC3 (.ac3) MP4 (.m4a)	

Audio Codec	Sample rate	Channel	Bit Rate	Container	Remark
EAC3	32KHz, 44.1KHz, 48KHz	Up to 5.1	32Kbps ~ 6Mbps	Movie: MP4 (.mp4, .mov) MPEG transport stream (.ts, .tp) MPEG program stream (.MPG, .MPEG) Music: EAC3 (.ec3) MP4 (.m4a)	
AAC-LC, HEAAC	8KHz ~ 48KHz	Up to 5.1	AAC-LC: 12kbps ~ 576kbps V1: 6kbps ~ 288kbps V2: 3kbps ~ 144kbps	Movie: AVI (.avi) Matroska (.mkv) MP4 (.mp4, .mov) MPEG transport stream (.ts, .tp) MPEG program stream (.MPG, .MPEG) Music: AAC (.aac) MP4 (.m4a)	
WMA	8KHz ~ 48KHz	Up to 2	128bps ~ 320Kbps	Movie: ASF (.wmv) AVI (.avi) Matroska (.mkv, .mka) Music: ASF (.wma)	WMA 7, WMA 8, WMA 9 Standard
WMA 10 Pro M0	48KHz	Up to 2	< 192kbps	Movie: ASF (.wmv) AVI (.avi) Matroska (.mkv) Music: ASF (.wma)	No LBR mode
WMA 10 Pro M1	48KHz	Up to 5.1	< 384kbps	Movie: ASF (.wmv) AVI (.avi) Matroska (.mkv) Music: ASF (.wma)	
WMA 10 Pro M2	96KHz	Up to 5.1	< 768kbps	Movie: ASF (.wmv) AVI (.avi) Matroska (.mkv) Music: ASF (.wma)	
VORBIS	Up to 48KHz	Up to 2		Movie: Matroska (.mkv) WebM (.webm) MP4 (.mp4, .mov) Music: MP4 (.m4a)	Supports stereo decoding only

Audio Codec	Sample rate	Channel	Bit Rate	Container	Remark
DTS	Up to 48KHz	Up to 5.1	<1.5Mbps	Movie: MPEG transport stream (.ts, .tp) MPEG program stream (.MPG, .MPEG) Matroska (.mkv)	
LPCM	8KHz ~ 48KHz	Up to 5.1	64Kbps ~ 1.5Mbps	Movie: AVI (.avi) Matroska (.mkv) MP4 (.mp4, .mov) MPEG transport stream (.ts, .tp) MPEG program stream (.MPG, .MPEG) Music: WAV (.wav) MP4 (.m4a)	
IMA-ADPCM MS-ADPCM	8KHz ~ 48KHz	Up to 2	32Kbps ~ 384Kbps	Movie: AVI (.avi) Matroska (.mkv) MP4 (.m4a, .mov) Music: WAV (.wav) MP4 (.m4a)	
G711 A/mu-law	8KHz	Up to 2	64Kbps	Movie: AVI (.avi) Matroska (.mkv) MP4 (.m4a, .mov) Music: WAV (.wav) MP4 (.m4a)	

Other Restrictions

- Video content will not play, or not play correctly, if there is an error in the content or the container.
- Sound or video may not work if the contents have a standard bit rate/frame rate above the compatible Frame/sec listed in the table.
- If the Index Table is in error, the Seek (Jump) function is not supported.
- Some USB/digital camera devices may not be compatible with the player.
- The menu can be displayed late if the video is over 10Mbps(bit rate).
- HEVC codec is only available in MKV/MP4/TS containers.

Full available resolution

Optimal resolution: 1366 x 768@60Hz.

See specification page for full available resolution.

HDMI Input (DTV)

Resolution	Horizontal Frequency (KHz)	Vertical Frequency (Hz)
640*480p	31.47	59.94
	31.50	60.00
720(1440)*480i	15.73	59.94
	15.75	60.00
720*480p	31.47	59.94
	31.50	60.00
720(1440)*576i	15.63	50.00
720*576p	31.25	50.00
1280*720p	44.96	59.94
	45.00	60.00
	37.50	50.00
1920*1080i	33.72	59.94
	33.75	60.00
	28.13	50.00
1920*1080p	67.43	59.94
	67.50	60.00
	56.25	50.00
	26.97	23.976
	27.00	24.00
	33.72	29.97
	33.75	30.00

HDMI Input (PC)

Resolution	Horizontal Frequency (KHz)	Vertical Frequency (Hz)
720*400	31.469	70.08
640*480	31.469	59.94
800*600	37.879	60.31
1024*768	48.363	60.00
1280*720	45.00	60.00
1360*768	47.712	60.015
1366*768	47.712	59.79